



STUMPF

PERFORMANCE

HENDREEL HENRICO

ALTA TECNOLOGIA PARA O MELHOR DESEMPENHO



SUMÁRIO

1. TABELA COM DADOS DE FLUXO	3
2. GRAFICOS DE FLUXO	4
3. CHECK LIST DO PRODUTO	5
4. ORÇAMENTO	6



TABELA COM DADOS DE FLUXO A 28"

FLOW PRO Report

Pg 1

Operator	Customer	Max CFM	Avg CFM
STUMPF CABEÇOTE	STUMPF CAB	126,6	94,5

GRAFICO DE FLUXO - CABEÇOTE STREET PRO - TESTE DE ESCAPE
A 28".

Lift	CCFM
2,00	33,2
4,00	70,1
6,00	100,0
8,00	114,7
10,00	122,6
12,00	126,6
Average:	94,5



GRAFICOS DE FLUXO A 28"

Flow Pro Graph

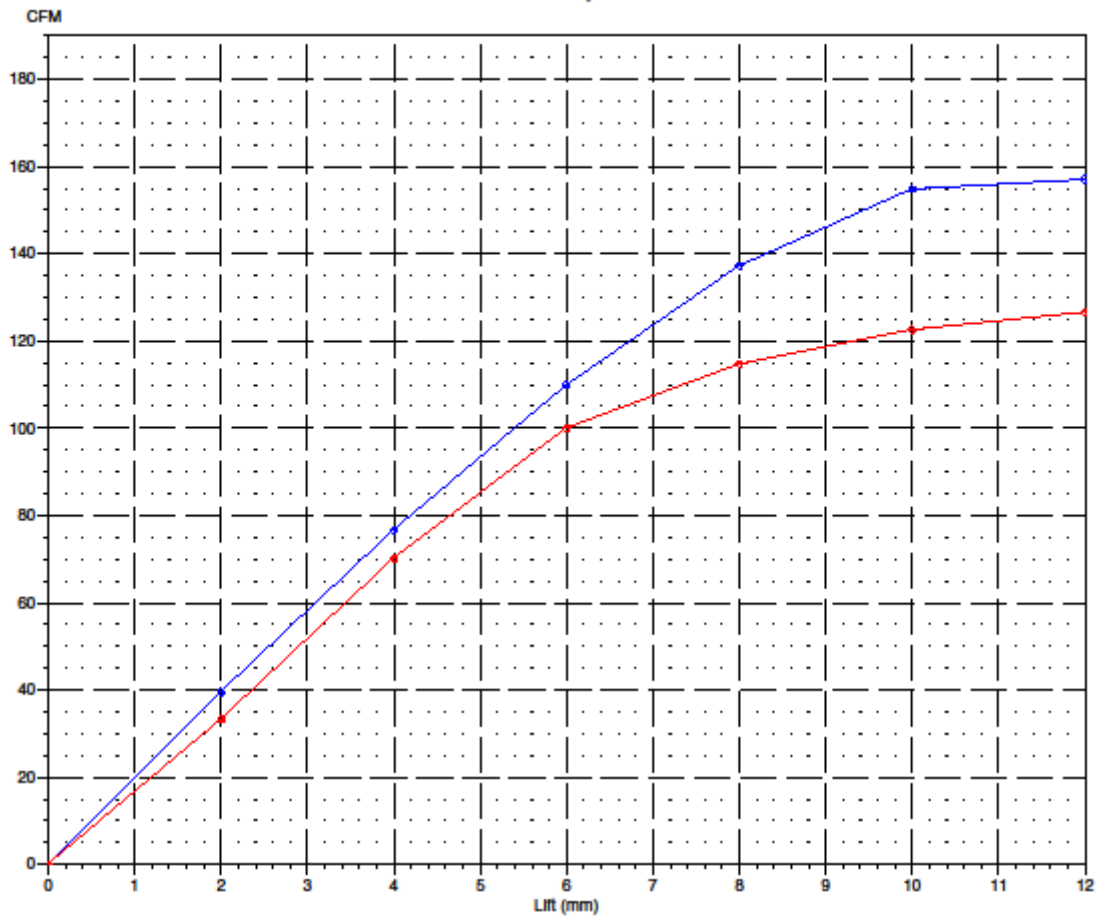

Int/Exh	Avg CFM	Time	Test No.
Exhaust	112,5	11:14	6092
GRAFICO DE FLUXO - CABEÇOTE STREET PRO - TESTE DE ADMISSÃO A 28".			
Exhaust	94,5	11:28	6094
GRAFICO DE FLUXO - CABEÇOTE STREET PRO - TESTE DE ESCAPE A 28".			

GRAFICO DE FLUXO - CABEÇOTE STREET PRO



CHECK LIST

CLIENTE: HENDREEL HENRICO
VISTORIA: VINICIUS

FOLGA VÁLV.	1	2	3	4	5	6	7	8
ADM	30	30	30	30	-	-	-	-
ESC	35	35	35	35	-	-	-	-

CARGA MOLAS	1	2	3	4	5	6	7	8
ADM	130/248	130/248	130/248	130/248	-	-	-	-
ESC	130/248	130/248	130/248	130/248	-	-	-	-

VED. SEDES	1	2	3	4	5	6	7	8
ADM	√	√	√	√	-	-	-	-
ESC	√	√	√	√	-	-	-	-

OBS>

VOLUME DA CAMARA 35,8 CC



DADOS DO COMANDO

CAM PRO PLUS Valve Lift Report

Pg 1

		C:\Cam Pro Plus\CPP\COMANDO SAMCAMS\350T.CPP				
		LIFT	DUR.	OPEN	CLOSE	AREA
Lobe	I1					
Centerline	112,21 BTDC	0,10	290,99	78,68 BBDC	32,31 ATDC	1027,6
.050 Lift C/L	112,18 BTDC	0,15	287,96	77,03 BBDC	30,93 ATDC	1027,3
Runout	0,0457	0,20	285,17	75,54 BBDC	29,63 ATDC	1027,0
Peak Open Acc.	0,01370	0,25	282,65	74,13 BBDC	28,52 ATDC	1026,7
Peak Nose Acc.	-0,00836	0,30	280,38	72,93 BBDC	27,46 ATDC	1026,3
Peak Close Acc.	0,01430	0,51	272,29	68,63 BBDC	23,66 ATDC	1024,4
Lift @ TDC	2,882	1,27	252,31	58,21 BBDC	14,10 ATDC	1015,2
Valve Lash	0,300	2,54	229,01	46,29 BBDC	2,72 ATDC	991,9
Rocker Ratio	1,00	7,65	148,58	5,68 BBDC	37,09 BTDC	780,7
Lobe Separation	112,2	8,89	125,51	5,69 ABDC	48,81 BTDC	683,9
		10,16	97,48	19,61 ABDC	62,92 BTDC	548,8
		11,43	57,95	39,15 ABDC	82,90 BTDC	333,2
		12,4223	---	PEAK CAM LIFT	---	
		12,1223	---	PEAK VALVE LIFT	---	

		C:\Cam Pro Plus\CPP\COMANDO SAMCAMS\350T.CPP				
		LIFT	DUR.	OPEN	CLOSE	AREA
Lobe	E1					
Centerline	112,21 ATDC	0,10	287,61	32,31 BTDC	75,30 ABDC	1026,2
.050 Lift C/L	112,39 ATDC	0,15	284,85	30,84 BTDC	74,00 ABDC	1025,8
Runout	0,0330	0,20	282,36	29,50 BTDC	72,87 ABDC	1025,8
Peak Open Acc.	0,01423	0,25	280,07	28,28 BTDC	71,79 ABDC	1025,6
Peak Nose Acc.	-0,00728	0,30	277,95	27,14 BTDC	70,81 ABDC	1025,3
Peak Close Acc.	0,01485	0,51	270,38	23,08 BTDC	67,30 ABDC	1023,7
Lift @ TDC	2,702	1,27	251,10	13,05 BTDC	58,05 ABDC	1014,1
Valve Lash	0,350	2,54	227,99	1,32 BTDC	46,67 ABDC	993,7
Rocker Ratio	1,00	7,65	148,73	38,37 ATDC	7,10 ABDC	790,5
Lobe Separation	112,2	8,89	125,84	49,77 ATDC	4,39 BBDC	695,7
		10,16	97,92	63,69 ATDC	18,39 BBDC	562,4
		11,43	59,01	82,99 ATDC	38,01 BBDC	351,4
		12,4980	---	PEAK CAM LIFT	---	
		12,1480	---	PEAK VALVE LIFT	---	



GRAFICO DO COMANDO

Cam Pro Plus Graph

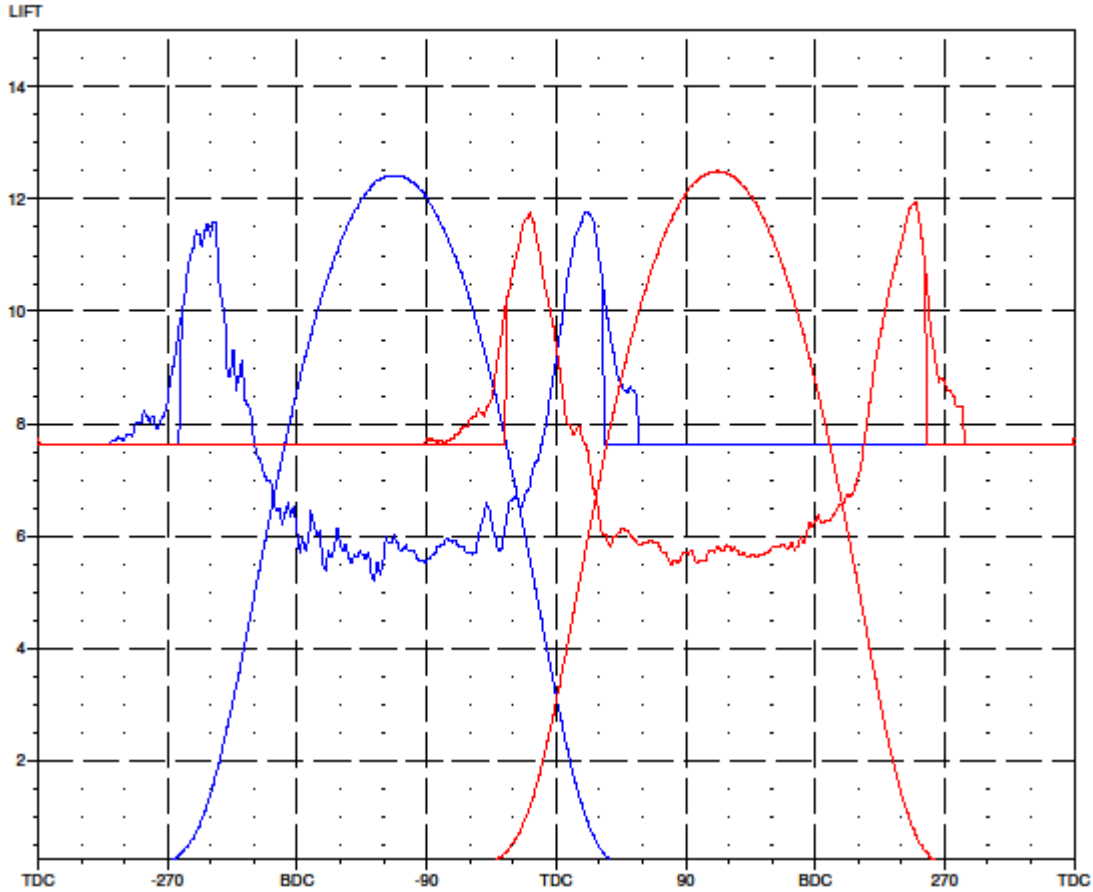

I/E	FILE	RUNOUT	LASH	RR	CENTERLINE	VALVE LIFT @ TDC
I1	350T.CPP comando 350t	0,046	0,30	1,00	-112,21 ATDC	2,882
E1	350T.CPP comando 350t	0,033	0,35	1,00	-112,21 BTDC	2,702

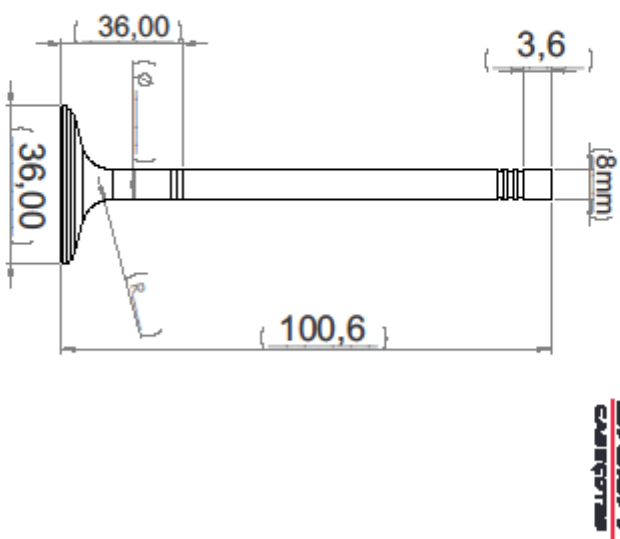

CHECK - LIST VALVULAS

	
Material: Inox Nacional	Responsável Téc.:
Trovas: () 3 Trovas (X) 1 Trova	Quantidade: 04
	Condição: (x) Sim () Não

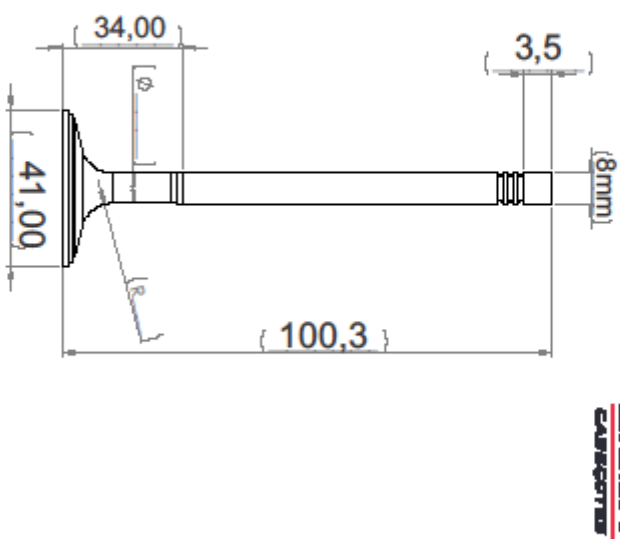
	
Material: Inox Nacional	Responsável Téc.:
Trovas: () 3 Trovas (X) 1 Trova	Quantidade: 04
	Condição: (x) Sim () Não



ORÇAMENTO



STUMPF
Tel/Fax: (45)99948-0123
RUA CARLOS CAVALCANTI, 474 - CASCAVEL / PR
CEP: 85818670 CNPJ: 33826228000194
E-mail: cabecotesstumpf@gmail.com

Data: 27/01/2026

ORÇAMENTO

Nº 23.529

O.S.: 449.465.157.129

Cliente: HENDREEL HENRICO SCHULTZ TEIXEIRA

CPF/CNPJ: 48339647830

Fone: (019)99224-721 Fone 2:

Endereço:

Veículo:

Placa:

DESCRIÇÃO DAS PEÇAS E/OU SERVIÇOS

Cod.	Descrição	Quant.	UN
1.096	RETENTOR DO COMANDO	1,0	UN
1.939	VALVULA INOX NACIONAL ESCAPE	4,0	UN
1.944	VALVULA INOX NACIONAL ADMISSAO	4,0	UN
1.084	GUIA 8MM	8,0	UN
1.037	TRAVA DE VALVULA DE ACO HASTE 8MM	16,0	UN
1.150	VEDADOR 8MM	8,0	UN
1.269	MATERIAL DE LIMPEZA	1,0	SE
1.159	PLAINA FACE	1,0	SE
1.210	MAO DE OBRA RETRABALHO AP 8V	1,0	MO
1.032	PRATO DE ALUMINIO H8	8,0	UN
1.186	RETIFICA DE SEDE	8,0	SE
1.179	PLAINA LATERAL	1,0	SE
1.111	MOLA LONGA	8,0	UN
1.049	CASCO AP ZERO	1,0	UN
1.530	SEDE DE ACO FORJADO	8,0	UN
1.187	SUBSTITUIR SEDE	8,0	SE
1.283	NITROGENIO PARA SEDES	8,0	UN
2.211	TUCHO 35MM	8,0	UN
1.468	COMANDO NACIONAL- 350T	1,0	UN
1.290	CAMISETA STUMPF DUAS GG	2,0	UN
2.554	KIT INSTALACAO	1,0	4
2.856	JUNTA.ADMISSAO AP 8V UNILATERAL	1,0	UN
2.422	BUJAO NPT 1/4	1,0	UN

