



STUMPF

PERFORMANCE

NICOLAS VITURRO

ALTA TECNOLOGIA PARA O MELHOR DESEMPENHO



SUMÁRIO

1. TABELA COM DADOS DE FLUXO	3
2. GRAFICOS DE FLUXO	4
3. CHECK LIST DO PRODUTO	5
4. ORÇAMENTO	6



TABELA COM DADOS DE FLUXO A 28"

FLOW PRO Report

Pg 1

Operator	Customer	Max CFM	Avg CFM
STUMPF CABEÇOTE	JLCAR MECA	126,6	94,5

GRAFICO DE FLUXO - CABEÇOTE RACING PRO TURBO BV - TESTE DE ESCAPE A 28".

Lift	CCFM
2,00	33,2
4,00	70,1
6,00	99,7
8,00	114,7
10,00	122,6
12,00	126,6
Average:	94,5



GRAFICOS DE FLUXO A 28"

Flow Pro Graph

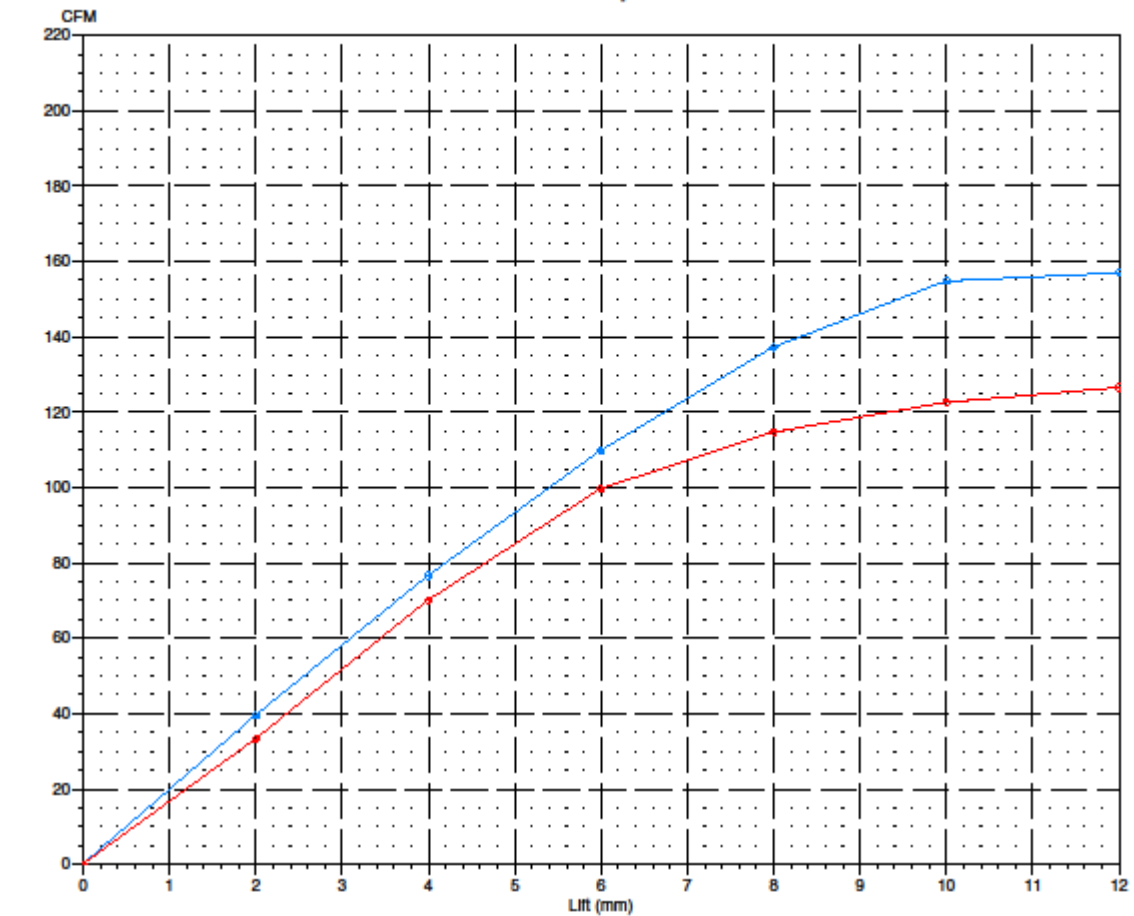

Int/Exh	Avg CFM	Time	Test No.
Exhaust	112,5	08:48	6014
TESTE DE FLUXO - CABEÇOTE RACING PRO TURBO 8V - TESTE DE ADMISSÃO A 28".			
Exhaust	94,5	08:54	6015
GRAFICO DE FLUXO - CABEÇOTE RACING PRO TURBO 8V - TESTE DE ESCAPE A 28".			

GRAFICO DE FLUXO - CABEÇOTE 8V RACING PRO TURBO - TESTE DE ADMISSÃO A 28"



CHECK LIST

CLIENTE: NICOLAS VITURRO
VISTORIA: ANDERSON

FOLGA VÁLVS.	1	2	3	4	5	6	7	8
ADM	35	35	35	35	-	-	-	-
ESC	40	40	40	40	-	-	-	-

CARGA MOLAS	1	2	3	4	5	6	7	8
ADM	140/300	140/300	140/300	140/300	-	-	-	-
ESC	140/300	140/300	140/300	140/300	-	-	-	-

VED. SEDES	1	2	3	4	5	6	7	8
ADM	-	-	-	-	-	-	-	-
ESC	-	-	-	-	-	-	-	-

OBS>	36,8 CC
----------------	----------------



DADOS DO COMANDO

CAM PRO PLUS Valve Lift Report

Pg 1

C:\Cam Pro Plus\CPP\COMANDOS STUMPF\STU TST.CPP

Lobe		LIFT	DUR.	OPEN	CLOSE	AREA
Centerline	I1 116,37 BTDC	0,15	278,70	75,41 BBDC	23,28 ATDC	1182,0
.050 Lift C/L	114,87 BTDC	0,51	267,88	69,13 BBDC	18,75 ATDC	1180,0
Runout	0,0330	1,27	255,21	62,40 BBDC	12,81 ATDC	1173,7
Peak Open Acc.	0,03459	2,54	238,20	53,74 BBDC	4,46 ATDC	1156,4
Peak Nose Acc.	-0,00848	3,81	221,79	45,43 BBDC	3,65 BTDC	1129,1
Peak Close Acc.	0,03797	5,08	205,07	37,11 BBDC	12,04 BTDC	1095,7
Lift @ TDC	3,242	6,35	187,68	28,41 BBDC	20,74 BTDC	1039,5
Valve Lash	0,300	7,62	169,33	19,21 BBDC	29,88 BTDC	974,2
Lobe Separation	116,4	8,89	149,61	9,59 BBDC	39,98 BTDC	891,5
		10,16	127,68	1,14 ABDC	51,18 BTDC	785,5
		11,43	101,19	13,99 ABDC	64,82 BTDC	641,0
		12,70	65,90	31,31 ABDC	82,79 BTDC	426,1
		13,9260		---	PEAK CAM LIFT	---
		13,6260		---	PEAK VALVE LIFT	---

C:\Cam Pro Plus\CPP\COMANDOS STUMPF\STU TST.CPP

Lobe		LIFT	DUR.	OPEN	CLOSE	AREA
Centerline	E1 116,37 ATDC	0,15	290,23	29,40 BTDC	80,84 ABDC	1247,0
.050 Lift C/L	117,05 ATDC	0,51	277,37	22,17 BTDC	75,20 ABDC	1245,0
Runout	0,0406	1,27	263,39	14,47 BTDC	68,92 ABDC	1239,0
Peak Open Acc.	0,02902	2,54	246,05	5,47 BTDC	60,58 ABDC	1222,6
Peak Nose Acc.	-0,00820	3,81	229,54	2,84 ATDC	52,38 ABDC	1196,4
Peak Close Acc.	0,03779	5,08	212,83	11,16 ATDC	43,99 ABDC	1159,2
Lift @ TDC	3,374	6,35	195,76	19,62 ATDC	35,37 ABDC	1110,4
Valve Lash	0,300	7,62	177,84	28,38 ATDC	26,22 ABDC	1040,1
Lobe Separation	116,4	8,89	158,27	38,04 ATDC	16,30 ABDC	957,9
		10,16	136,37	48,85 ATDC	5,22 ABDC	862,5
		11,43	110,42	61,62 ATDC	7,96 BBDC	710,7
		12,70	77,10	78,14 ATDC	24,76 BBDC	520,5
		14,2074		---	PEAK CAM LIFT	---
		13,9074		---	PEAK VALVE LIFT	---

DADOS COMANDO STU TST



GRAFICO DO COMANDO

Cam Pro Plus Graph

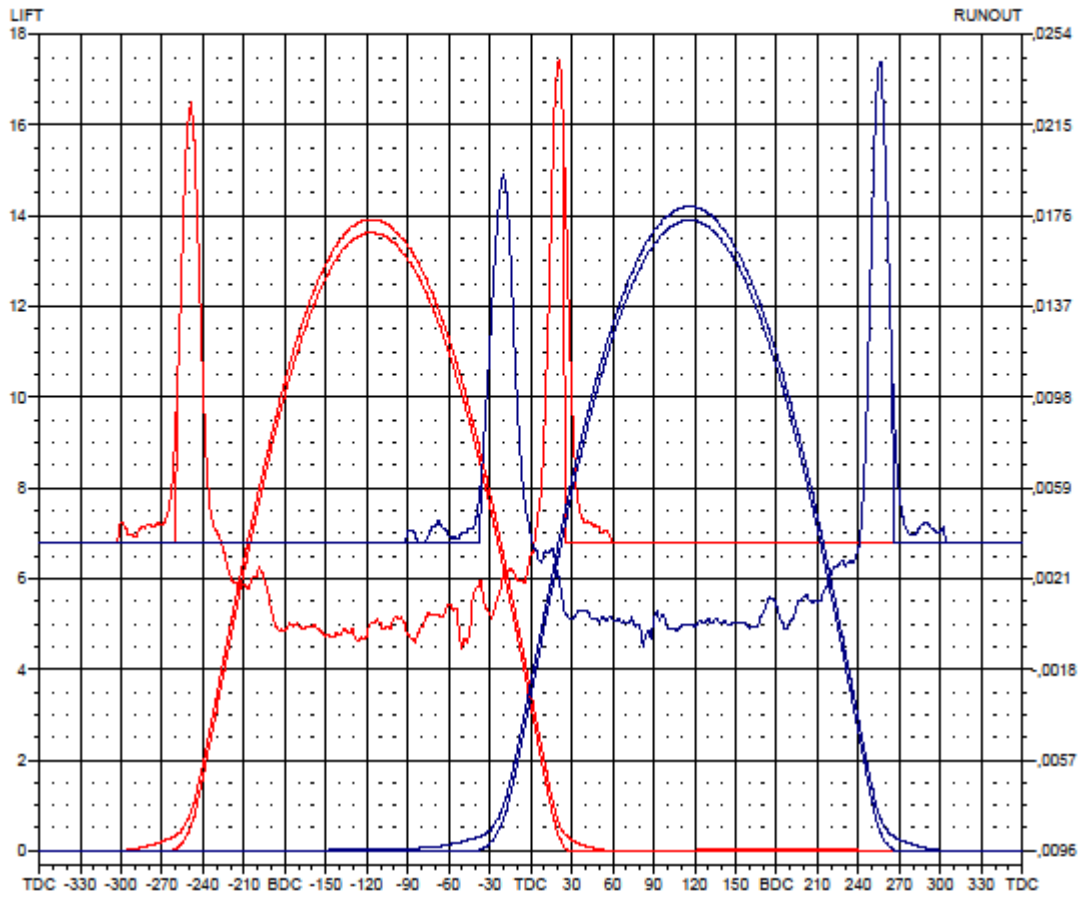

I/E	FILE	RUNOUT	LASH	RR	CENTERLINE	VALVE LIFT @ TDC
I1	STU TST.CPP	0,033	0,30	1,00	-116,37 ATDC	3,242
E1	STU TST.CPP	0,041	0,30	1,00	-116,37 BTDC	3,374

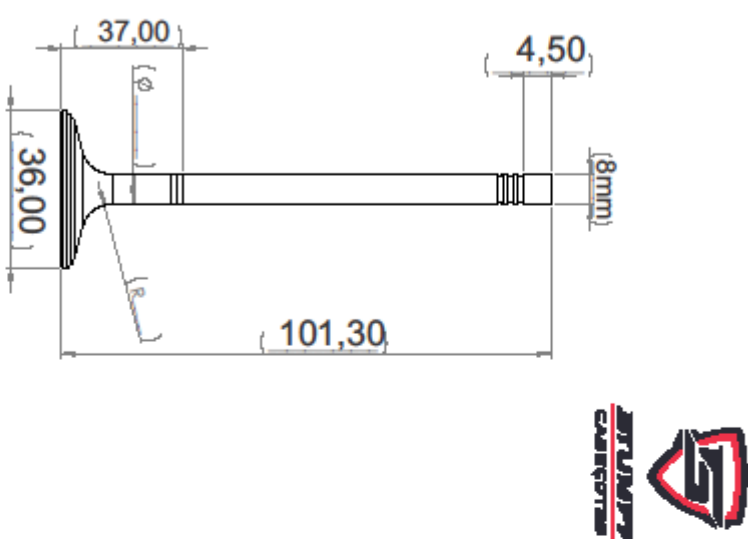

CHECK - LIST VALVULAS

	
Material: Inox Nacional	Responsável Téc.: Anderson
Trovas: () 3 Trovas (X) 1 Trova	Quantidade: 04
	Corridade: (x) Sim () Não

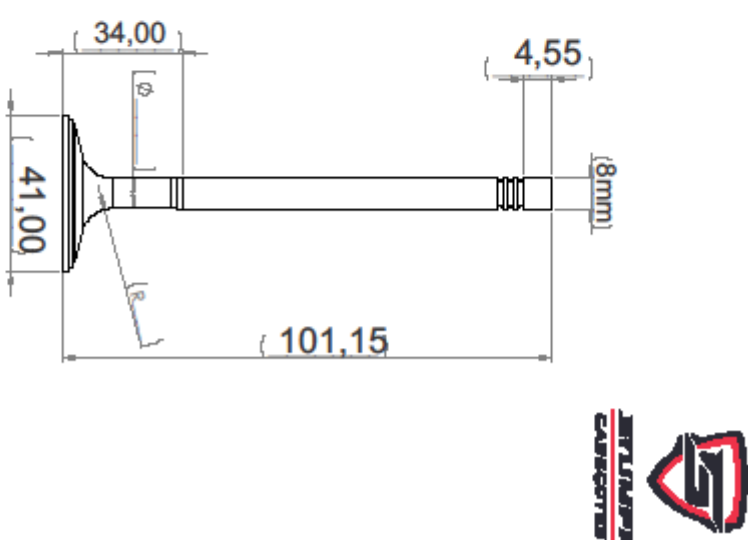
	
Material: Inox Nacional	Responsável Téc.: Anderson
Trovas: () 3 Trovas (X) 1 Trova	Quantidade: 04
	Corridade: (x) Sim () Não



ORÇAMENTO



STUMPF
Tel/Fax: (45)99948-0123
RUA CARLOS CAVALCANTI, 474 - CASCAVEL / PR
CEP: 85818670 CNPJ: 33826228000194
E-mail: cabecotesstumpf@gmail.com

Data: 16/01/2026

ORÇAMENTO

Nº 23.419

O.S.: 449.465.158.123

Cliente: NICOLAS VITURRO

CPF/CNPJ:

Fone:

Fone 2:

Endereço:

Veículo:

Placa:

DESCRIÇÃO DAS PEÇAS E/OU SERVIÇOS

Cod.	Descrição	Quant.	UN
1.269	MATERIAL DE LIMPEZA	1,0	SE
1.159	PLAINA FACE	1,0	SE
1.187	SUBSTITUIR SEDE	8,0	SE
1.210	MAO DE OBRA RETRABALHO AP 8V	1,0	MO
1.186	RETIFICA DE SEDE	8,0	SE
1.283	NITROGENIO PARA SEDES	8,0	UN
1.270	BUCHA DE REFORCO DO ESCAPE	2,0	UN
1.146	SEDE DE BERILIO	8,0	UN
1.192	ABRIR ALOJAMENTO DE TUCHO	8,0	SE
1.447	PLAINA LATERAL	2,0	SE
1.150	VEDADOR 8MM	8,0	UN
1.084	GUIA 8MM	8,0	UN
1.896	RETENTOR DO COMANDO	1,0	UN
2.212	TUCHO 37MM COM DLC- COM TETA DE 6.8 MM - ENVIAR SOLTO	16,0	UN
2.043	PARAFUSO ALLEN 1/8"	1,0	UN
1.057	CASCO F.C. ALEMAO - ZERO	1,0	UN
1.938	VALVULA INOX NACIONAL ADMISSAO	4,0	UN
1.948	VALVULA INOX NACIONAL ESCAPE	4,0	UN

